



Commercial Gas Convection Oven

Model	Burners
IRCO-1	3
IRCO-2	6

STANDARD FEATURES

Construction

- Stainless Steel Front, Sides and Angular Legs
- Double pane thermal glass windows on doors
- 6" caster kit included, two with lock, two without
- Doors have an interlock switch that automatically turns the fan and burners off when open
- 3/4" rear NPT gas connection

Oven Features

- 1/2 HP two speed fan motor
- 10 position guide rack with 1.5" spacing
- 5 heavy-duty adjustable chrome plated oven racks per oven cavity
- Easy to Clean Full Porcelain Oven Interior.
- Seamless Nano Porcelain interior and corners for easy cleaning and chip resistant

Control

- 120V, 60hz controls for oven
- Temperature range from 150°F - 550°F
- 60 minute continuous ring timer with manual shut off
- Temperature ready indicator light
- 6" power cord with NEMA 5-15 plug

Warranty: 1 year parts and labor

Note: Double Deck ovens are shipped as single decks

SPECIFICATIONS

Iron Range's Full Size Gas Convection Oven is ideal for any high volume restaurant or foodservice establishment. Constructed of stainless steel, this oven operates with a forced air, two-speed fan motor system with a cool down feature. The interior of the oven has a 10 position rack guide and fits full-size sheet pans. Electronic controls featuring a 60-minute timer and manual temperature knob. The double-pane glass doors have an interlock switch that automatically turns the fan and burners off when they are opened.

Units are shipped for natural gas but are easily converted to LPG (propane) gas with the LPG conversion kit that is included.

All Convection ovens carry ETL approval for gas and sanitation that pass USA requirements for use in food service.





IMPORTANT INFORMATION:

- A combination safety valve with built-in pressure regulator is provided with this unit. Natural Gas 4.0" (102 mm) W.C.
Propane Gas 10.0" (279 mm) W.C.
- Gas connection is 3/4" NPT (19mm) rear gas connection. If using Flex-Hose, the I.D for single deck should be minimum 3/4" and double deck 1" and must comply with ANSI Z 21.69
- All equipment is supplied for Natural Gas, an LPG conversion kit is also provided.

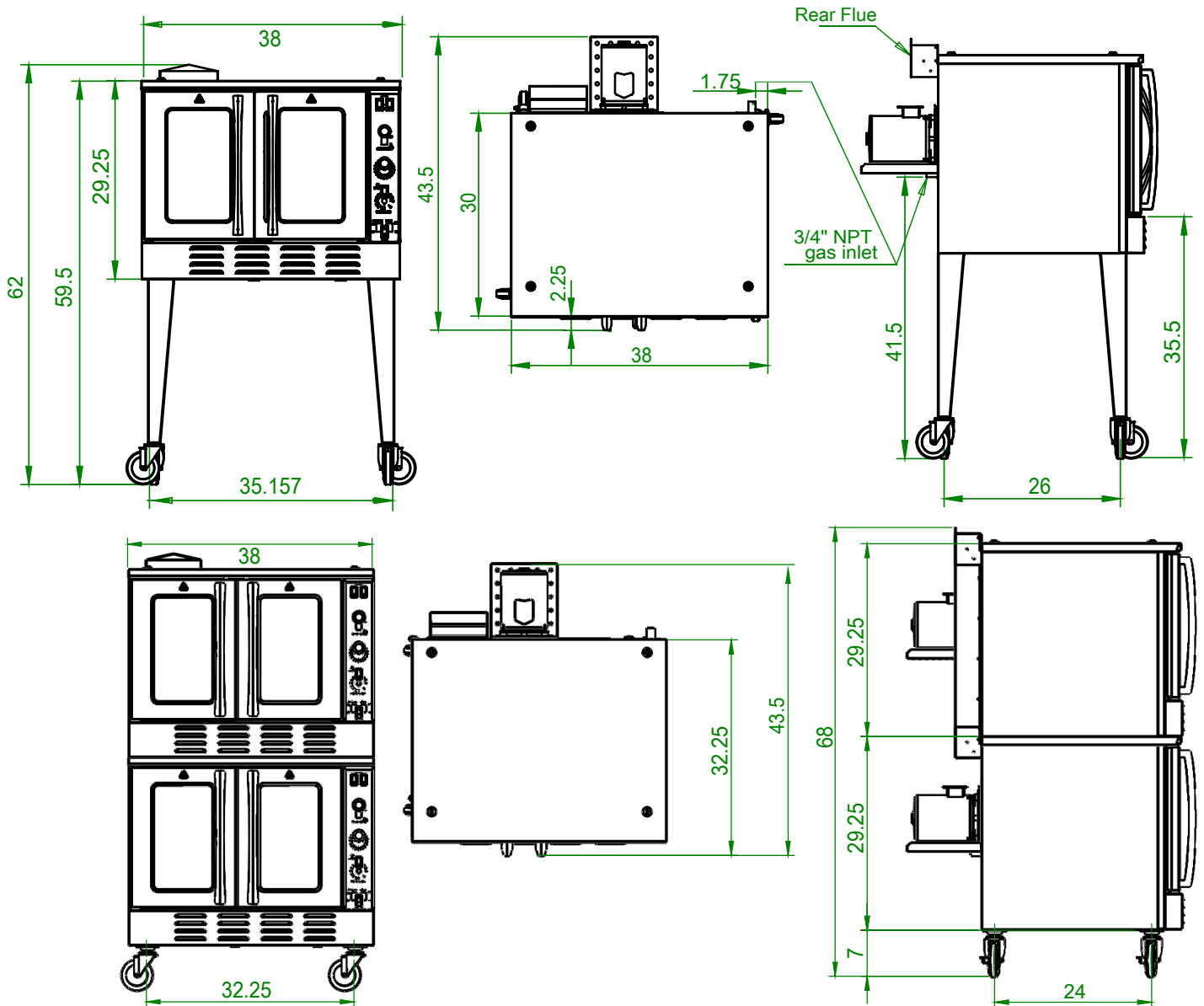

Model	Racks	External Dimensions			Internal Oven Dimensions			Total BTU's	AMP	Volts	Crated Weight (lbs)
		W	D	H	W	D	H				
IRCO-1	5	38	44	62	28.5	21.5	20	54,000	5.9	120V	579
IRCO-2	10	38	44	68	28.5	21.5	20	108,000	5.9 x 2	120V	1158

Specifications are subject to change without notice.

